

D05 Servo Valve Tapping Plates

D05-S1, D05-S2, D05-S3 Pilot Port Tapping Plate

Subplate interface seal kit is supplied.
See page 154 for itemized list.

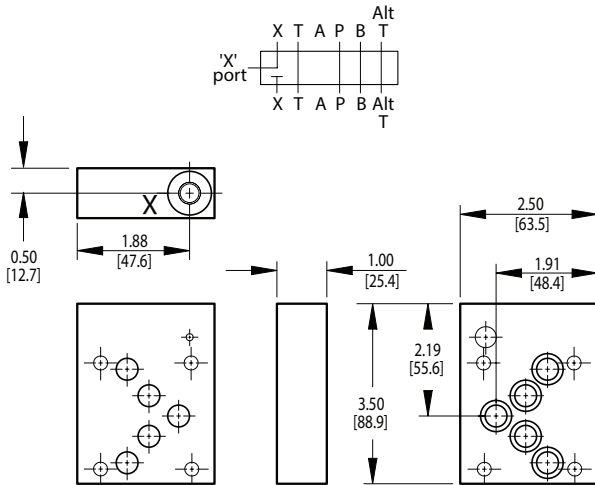

D05-S4 Pilot Port Tapping Plate

Subplate interface seal kit is supplied.
See page 154 for itemized list.

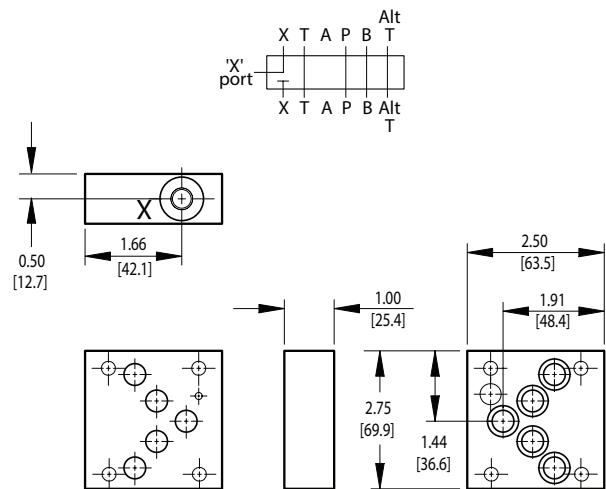

Note: These tapping plates are designed to be used with standard D05 manifolds or subplates. They provide an external pilot port for the servo valves referenced. If the servo valve uses an internal pilot, these tapping plates are not needed. The servo valve may be mounted directly to our D05 manifold or subplate.

Specifications, descriptions, and dimensional data are subject to correction or change without notice or incurring obligation. Download latest catalog page revisions at www.daman.com.

Ordering Information

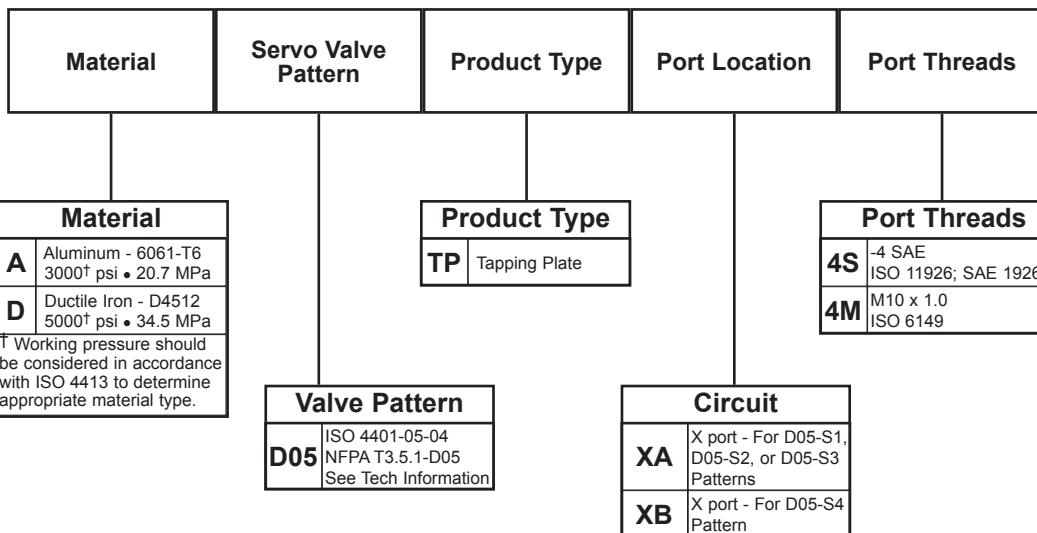

For **coating options** see pages 245-246.